

REVISION HISTORY			
REV	DATE	BY	DESCRIPTION
H	04JUN2018	NSB/DMS	PRN: P2018-1375

1.6 TO 12.7
[.063] [.500]

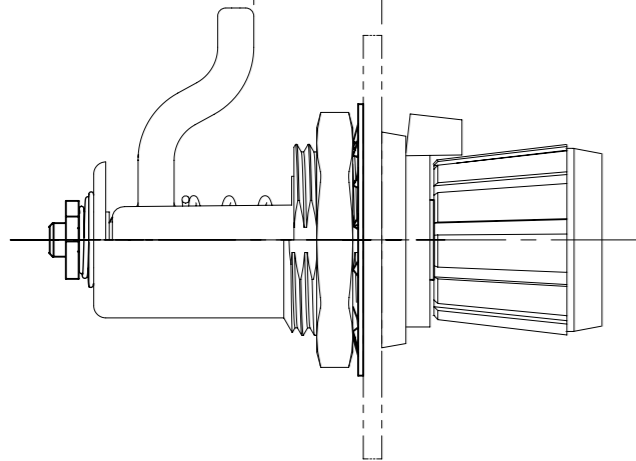

16-10-311-14

9.5 TO 20.6
[.374] [.813]

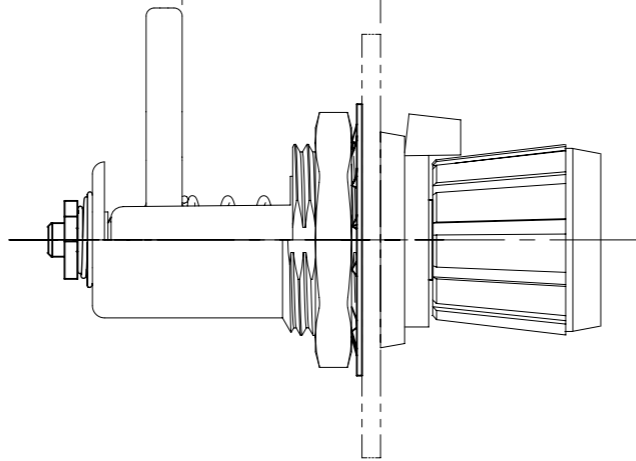

16-10-312-14

17.5 TO 28.6
[.689] [1.125]

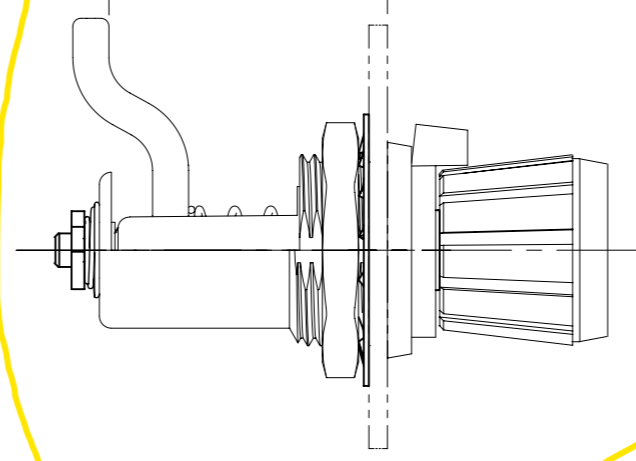

16-10-313-14

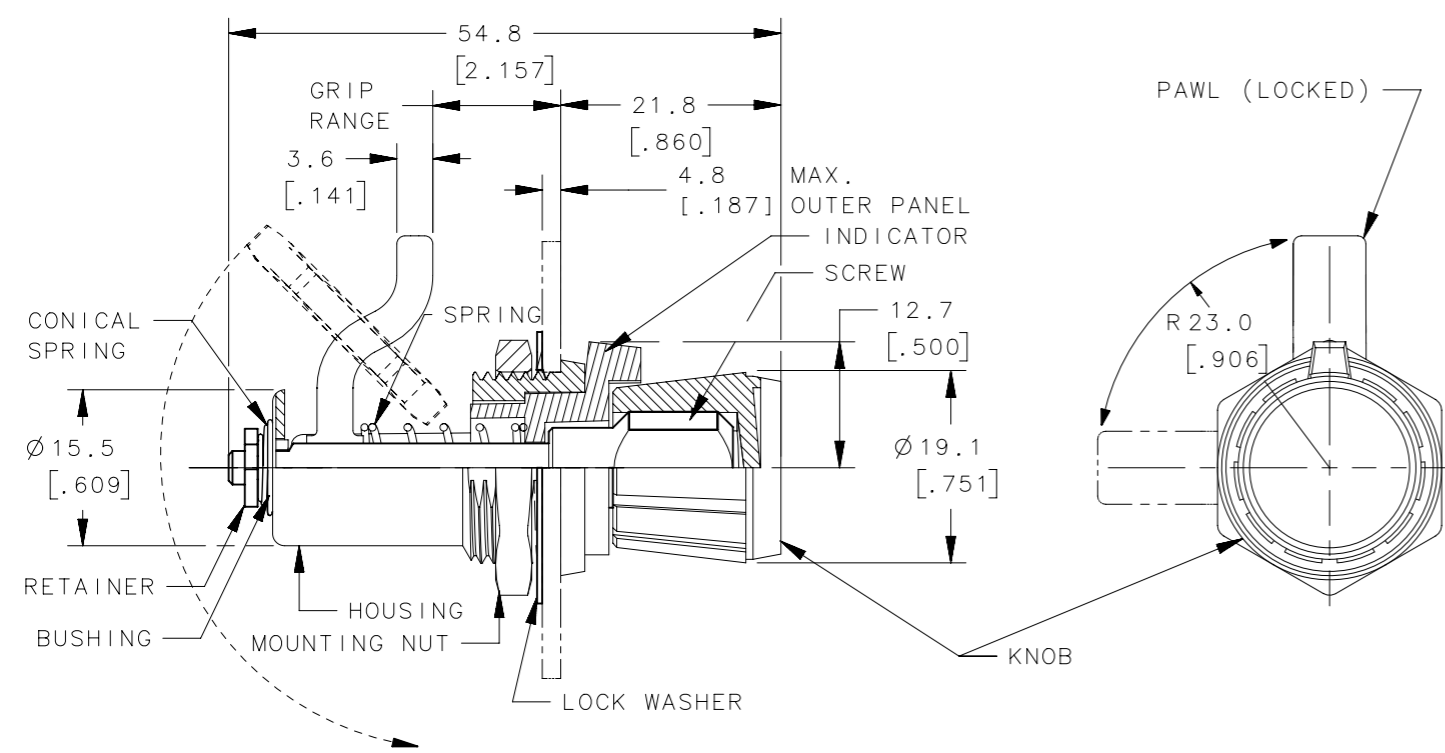
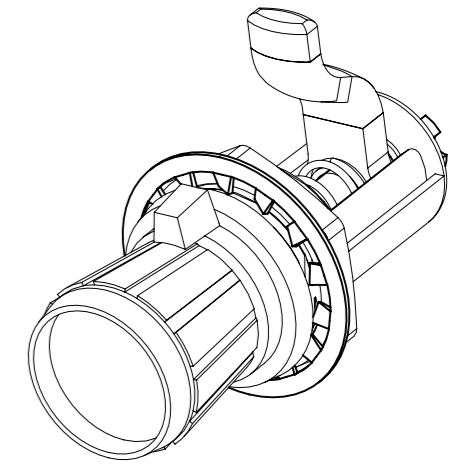

PANEL PREPARATION
ALTERNATE HOLE SHAPE -
Ø 19.1 [0.750] ROUND HOLE

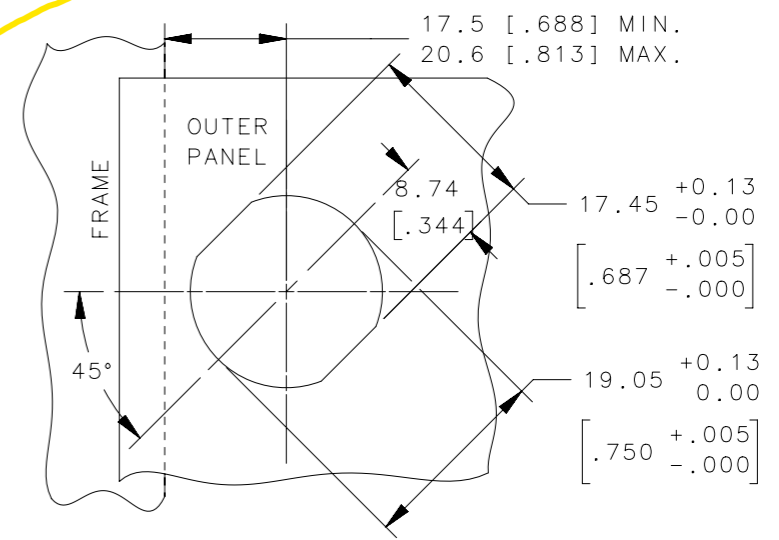

1	1	1	MOUNTING NUT	STEEL	ZINC PLATE PLUS BRIGHT CHROMATE
1	1	1	RETAINER	STEEL	ZINC PLATE PLUS BRIGHT CHROMATE PLUS SEALER
1	1	1	CONICAL SPRING	STAINLESS STEEL	PASSIVATED
1	1	1	BUSHING	STEEL	NATURAL
-	1	-	PAWL	DIE-CAST ZINC	CORICONE DIP
1	-	1	PAWL	DIE-CAST ZINC	CORICONE DIP
1	1	1	SPRING	STAINLESS STEEL	PASSIVATED
1	1	1	HOUSING	DIE-CAST ZINC	BRIGHT CHROMATE
1	1	1	PAWL INDICATOR	DIE-CAST ZINC	BRIGHT CHROMATE
1	1	1	KNOB SCREW ASSEMBLY	KNOB: THERMOPLASTIC SCREW: STEEL	BLACK BLACK ORGANIC COATING
1	1	1	LOCK WASHER	STEEL	DACROTIZED™
X	-	-	16-10-313-14	-	-
-	X	-	16-10-312-14	-	-
-	-	X	16-10-311-14	-	-
QTY.			ITEM	MATERIAL	FINISH

- NOTES:
- INSTALLATION INSTRUCTIONS:
 - REMOVE NUT AND LOCKWASHER FROM FASTENER ASSEMBLY.
 - PLACE FASTENER (PROPERLY ORIENTED) THRU MOUNTING HOLE AND SWING NUT AND LOCKWASHER OVER PAWL AND HOUSING AND THREAD ONTO HOUSING AND TIGHTEN.
 - THESE ASSEMBLIES ARE NON-REPAIRABLE ITEMS AND COMPONENTS ARE NOT AVAILABLE AS REPLACEMENT OR REPAIR PARTS.

THIRD ANGLE PROJECTION

MILLIMETERS [IN]

TOLERANCES UNLESS OTHERWISE NOTED

ALL DIMENSIONS WITHOUT TOLERANCES ARE FOR REFERENCE ONLY.

PROPRIETARY ITEM
EXCEPT FOR USES EXPRESSLY GRANTED IN WRITING, INFORMATION DISCLOSED HEREON IS CONFIDENTIAL AND ALL RIGHTS, PATENT AND OTHERWISE, ARE RESERVED BY SOUTHCO, INC.

PER ASME Y14.5M-1994

southco
CONNECT • CREATE • INNOVATE

DESCRIPTION
No. 16 FASTENER 310 SERIES
ADJUSTABLE PAWL FASTENER ASSEMBLY

SIZE A3 SYSTEM NX DWG NO. J-16-10-311-14

DRAWN BY RHB DATE 17OCT1974 SCALE 1:0.75 SHEET 1 OF 1